



DE VALK
YACHT BROKERS



DEHLER 41 DS



DE VALK
YACHT BROKERS

BROKER'S COMMENTS

The Dehler 41DS is a comfortable and fast cruisingyacht. As known from Dehler every design is well thought though and innovative. Resulting in an extremely easy to handle sailingyacht. With incorporated decksaloon and panoramic view, certainly a yacht for this "day and age" and very much up to date. "MIJLPAAL" comes very well equipped with electric winches, bowthruster, reefable selftacking jib. Making her ideal for "push-button-sailing" when wanted by a small crew.

Ger Bayens

SPECIFICATIONS

| | | | |
|---------------------|-------------------------|----------------|------------------------|
| Dimensions | 12.45 x 3.90 x 1.95 (m) | Builder | Dehler Yachtbau GmbH |
| Built | 2004 | Cabins | 2 |
| Material | GRP | Berths | 6 |
| Engine(s) | 1 x Yanmar 4JH4E Diesel | Hp/Kw | 56.00 (hp), 41.16 (kw) |
| Asking price | sold (VAT) | Lying | at sales office |

CONTACT

| | | | |
|---------------------|--|------------------|------------------------|
| Sales office | De Valk Sint Annaland B.V. | Telephone | +31 (0)166 601 000 |
| Address | Koelhuisweg 4 4697 RM Sint Annaland NL | E-mail | sintannaland@devalk.nl |

DISCLAIMER

These particulars are given in good faith as supplied but cannot be guaranteed.



DEHLER 41 DS

GENERAL

| | |
|--------------------------------|----------------------------|
| Model | DEHLER 41 DS |
| Type | sailing yacht |
| LOA (m) | 12,45 |
| LWL (m) | 11,05 |
| Beam (m) | 3,90 |
| Draft (m) | 1,95 |
| Air draft (m) | 19,50 |
| Headroom (m) | 1,95 |
| Year built | 2004 |
| Builder | Dehler Yachtbau GmbH |
| Country | Germany |
| Designer | Judel & Vrolijk |
| Displacement (t) | 8,9 |
| Ballast (tonnes) | cast iron and lead |
| CE norm | A |
| Hull material | GRP |
| Hull colour | blue |
| Hull shape | round-bilged |
| Keel type | fin keel with bulb |
| Superstructure material | GRP |
| Rubbing strake | |
| Deck material | GRP |
| Deck finish | TBS anti-slip profile mats |
| Cockpit deck finish | teak |
| Antifouling (year) | 2013 |
| Dorades | 2x |
| Window frame | aluminium |
| Window material | polycarbonate |
| Deckhatch | yes |
| Portholes | aluminium |



DEHLER 41 DS

| | |
|-------------------------------------|--|
| Fuel tank (litre) | stainless steel 160 Ltr. |
| Level indicator (fuel tank) | yes |
| Freshwater tank (litre) | polyethylene 400 Ltr in 2 tanks |
| Level indicator (freshwater) | yes |
| Blackwater tank (litre) | stainless steel |
| Level indicator (blackwater) | Not functioning |
| Blackwater tank extraction | deck extraction + uw line 65 |
| Wheel steering | mechanical |
| Emergency tiller | yes |
| More info on hull | Blue gelcoat |
| More info on paintwork | Epoxy water barrier paint system on uw hull from new |
| Extra info | Cover for steering pedestal |

ACCOMMODATION

| | |
|--------------------------------------|---|
| Cabins | 2 |
| Berths | 6 |
| Interior | cherry |
| Floor | woodprint |
| Deck saloon | yes |
| Headroom saloon (m) | 1,95 |
| Heating | diesel ducted hot air Webasto Airtop 5000 |
| Navigation center | yes |
| Chart table | yes |
| Aft Cabin | yes |
| Dinette | yes |
| Dinette to convert into berth | yes |
| Sliding door to cockpit | Patented Dehler System |
| Galley | yes |
| Countertop | plastic |
| Sink | stainless steel 2x |
| Cooker | calor gas 3-flame |



DEHLER 41 DS

| | |
|-----------------------|------------------------------|
| Oven | yes |
| Microwave | AFIX 220V |
| Fridge | with freezer compartment |
| Hot water system | 220V + engine |
| Water pressure system | electrical |
| Coffee maker | 220V |
| Crockery | yes |
| Owners cabin | double bed |
| Bed length (m) | Comfort mattress 1,97 |
| Wardrobe | hanging/drawers/shelves |
| Bathroom | en suite |
| Toilet | en suite |
| Toilet system | manual |
| Wash basin | at the toilet |
| Shower | en suite |
| Guest cabin 1 | double bed |
| Bed length (m) | 2,00 |
| Wardrobe | shelves and hanging |
| Bathroom | shared |
| Toilet | shared |
| Toilet system | manual |
| Wash basin | at the toilet |
| Shower | shared |
| Extra info | Alcantara cushions in saloon |

MACHINERY

| | |
|---------------|--------|
| No of engines | 1 |
| Make | Yanmar |
| Type | 4JH4E |
| HP | 56,00 |
| kW | 41,16 |



DEHLER 41 DS

| | |
|---------------------------------|---------------------------------------|
| Fuel | diesel |
| Year installed | 2004 |
| Maximum speed (kn) | 7,5 |
| Cruising speed (kn) | 7 |
| Consumption (l/hr) | 3 |
| Engine hours | 365 |
| Engine cooling system | freshwater heat exchanger |
| Drive | shaft |
| Engine controls | bowden cable |
| Gearbox | mechanical |
| Bowthruster | electric 50 Kgf |
| Exhaust | watercooled |
| Thrust bearing | Aquadrive |
| Propeller type | feathering Variprop SPW DF-112 |
| Propeller blades | 3 |
| Propeller shaft material | stainless steel |
| Shaft lubrication | water |
| Manual bilge pump | yes |
| Electric bilge pump | yes |
| Electrical installation | 12/220V |
| Batteries | 3x |
| Start battery | 1x 60 Ah |
| Service battery | 2x 200 Gel |
| Battery monitor | yes |
| Battery charger | Mastervolt IVO Smart 12V/40Ah |
| Inverter | 1000W |
| Shorepower | with cable |
| Extra info | Tricolour + anchor light in mastehead |

NAVIGATION

| | |
|----------------|--------|
| Compass | Suunto |
|----------------|--------|



| | |
|------------------------------------|---|
| Electric compass | Via Raymarine Autopilot |
| Depth sounder | Raymarine ST60 Tridata |
| Log | Raymarine ST60 Tridata |
| Windset | Raymarine ST60 |
| Repeater | RAYmarine Graphic |
| VHF | Plus full function handset im cockpit connection & speaker Raymarine 215 E |
| Autopilot | with remote control Raymarine 6001 |
| Wind vane steering install. | Connected with Windunit Raymarine 6001 |
| Rudder angle indicator | yes |
| GPS | Raymarine 435i |
| Plotter | Raymarine 435i |
| Electronis chart(s) | Needs update |

EQUIPMENT

| | |
|-----------------------------------|--------------------|
| Fixed windscreen | yes |
| Sprayhood | 2010 (+ old spare) |
| Sprayhood with grab rail | yes |
| Cockpit cover | 2010 (+ old spare) |
| Sun awning | yes |
| Cockpit table | yes |
| Bathing platform | Steps |
| Boarding ladder | stainless steel |
| Bow ladder | yes |
| Deck shower | yes |
| Anchor | Bruce 20Kg |
| Anchor chain | 30mtr |
| Windlass | electrical Lewmar |
| Sea railing | wire |
| Grab rail (superstructure) | yes |
| Railing side opening gates | yes |



| | |
|----------------------------|------------|
| Pushpit | yes |
| Pulpit | yes |
| Fenders | yes |
| Mooring lines | yes |
| TV | Flatscreen |
| TV receiver | Digitenne |
| Radio-cd player | Sony |
| Speakers in salon | yes |
| Clock - barometer | yes |
| Fire extinguisher | 2x |
| Latest extinguisher survey | Unknown |

RIGGING

| | |
|-------------------------------|---|
| Rigging | fractional |
| Standing rigging | wire |
| Brand mast | Sparcraft |
| Material mast | aluminium |
| Spreaders | 2 sets |
| Mainsail | Elvström |
| Mainsail cover | Dehler Main Drop System |
| Battcars | yes |
| Fully battened mainsail | Frederiksen |
| High aspect | Selftacking & Reefable Elvström Bi-Radial |
| Genoa furler | Furlex 300S |
| Genoa cover | yes |
| Self tacking jib installation | yes |
| Reefing System | slabreefing |
| Backstay adjuster | tackle |
| Boomvang | mechanical and tackle |
| Primary sheet winch | 12V E-winchs with dubbel control switches 2x Harken ST 445 E |



| | |
|--------------------------------|---|
| Reefing winch | reefing with multifunctional winches from cockpit |
| Multifunctional winches | halyard/sheet winches |
| Winchcovers | yes |
| Spi-pole | aluminium Jib-Pole |
| Extra info | Lower mast steps for easy mainsail handling |



DEHLER 41 DS



DEHLER 41 DS



DEHLER 41 DS

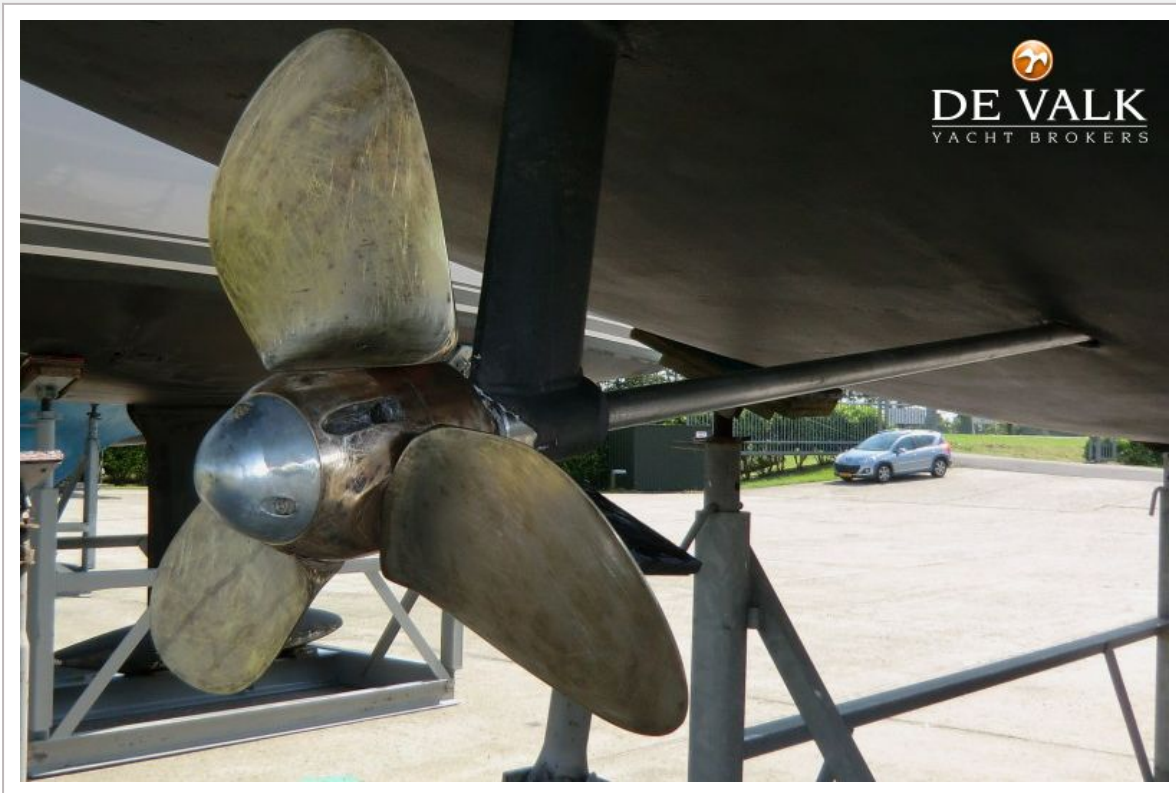

DEHLER 41 DS



DEHLER 41 DS



DEHLER 41 DS

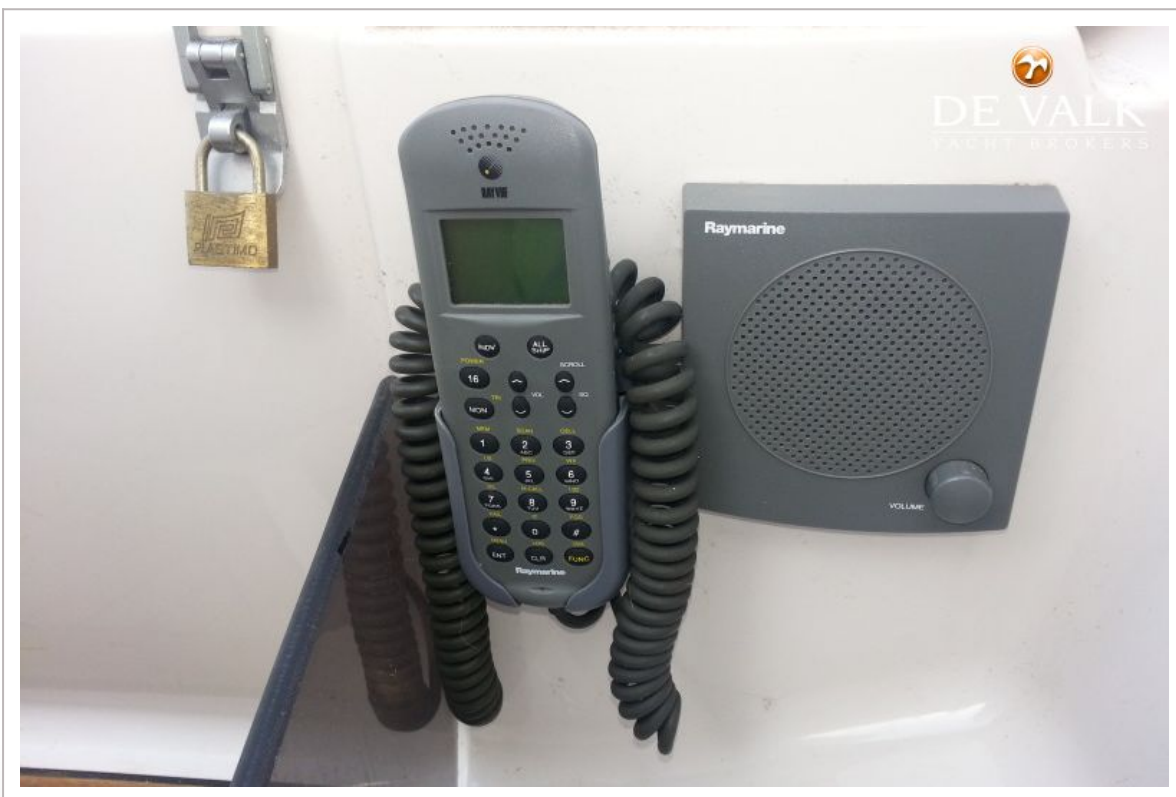

DEHLER 41 DS



DEHLER 41 DS

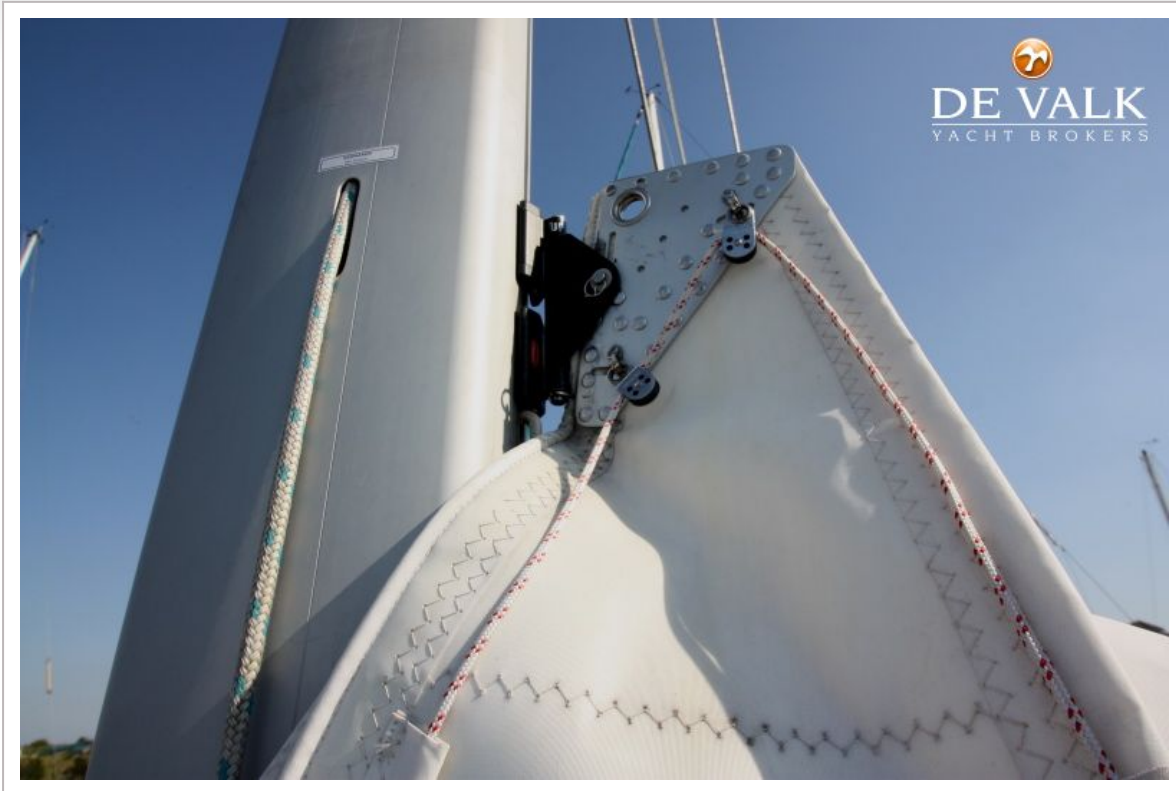

DEHLER 41 DS

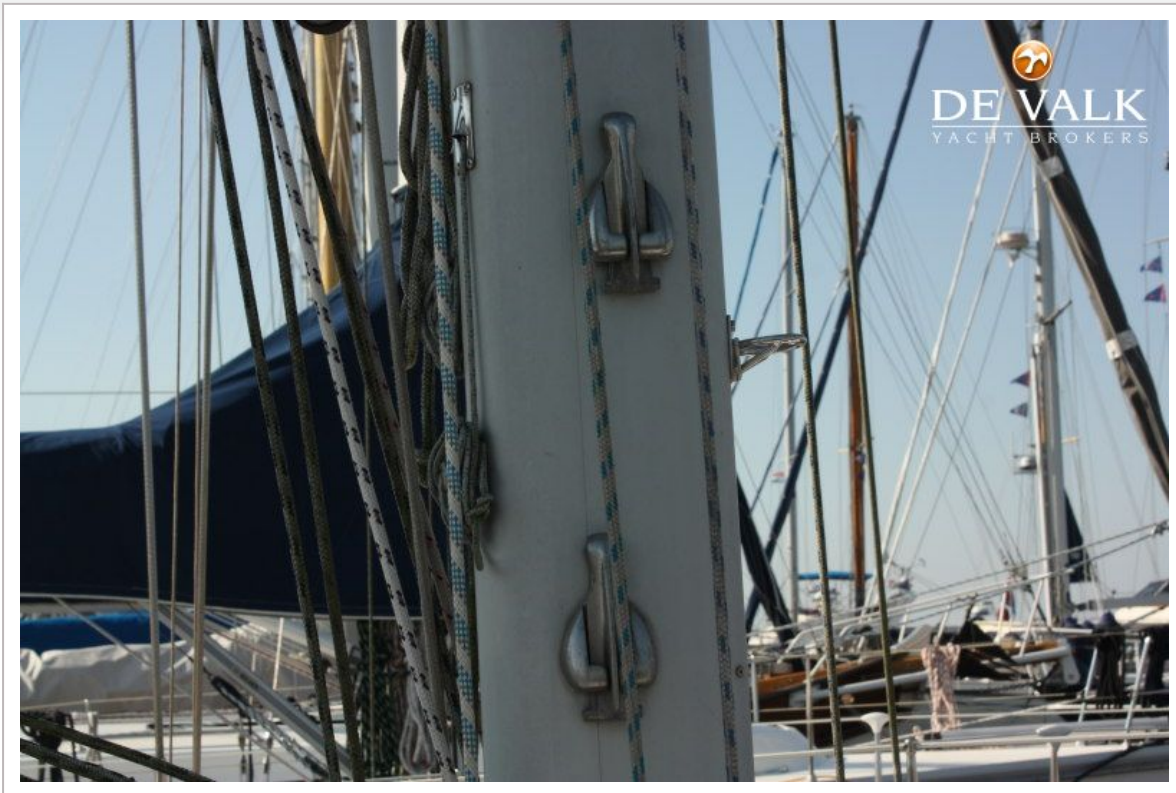

DEHLER 41 DS

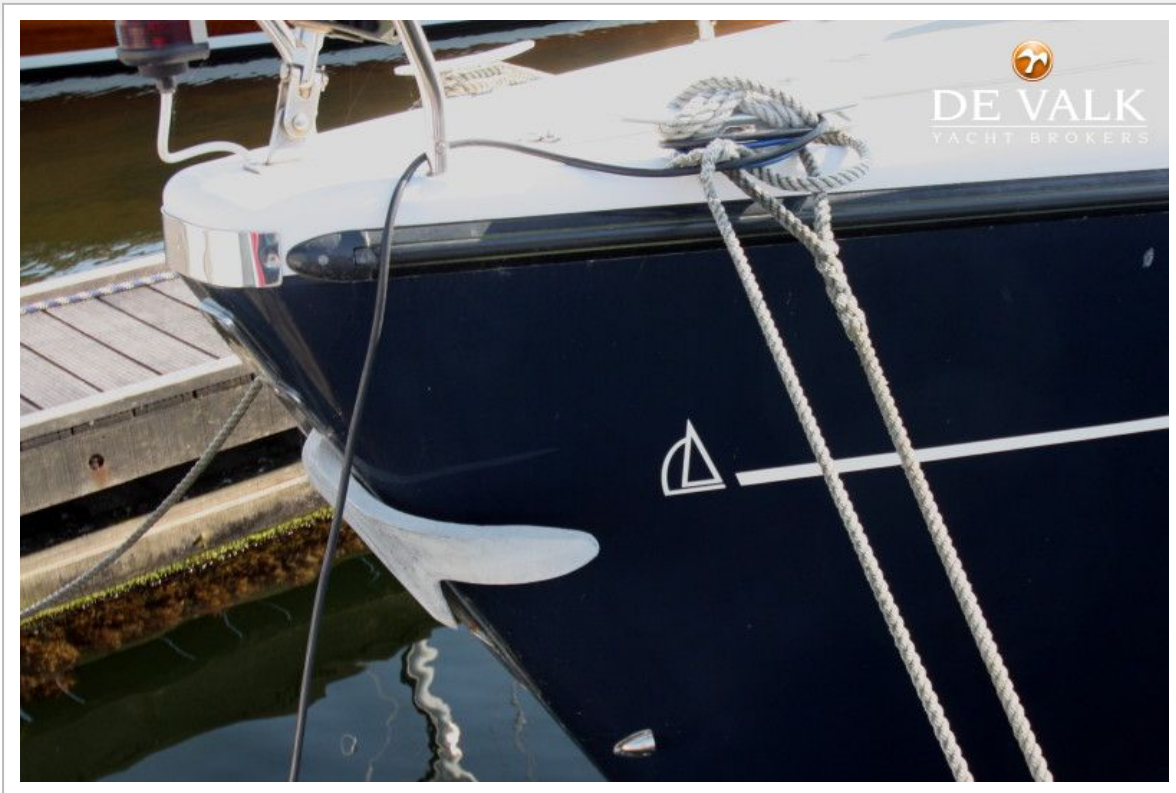

DEHLER 41 DS

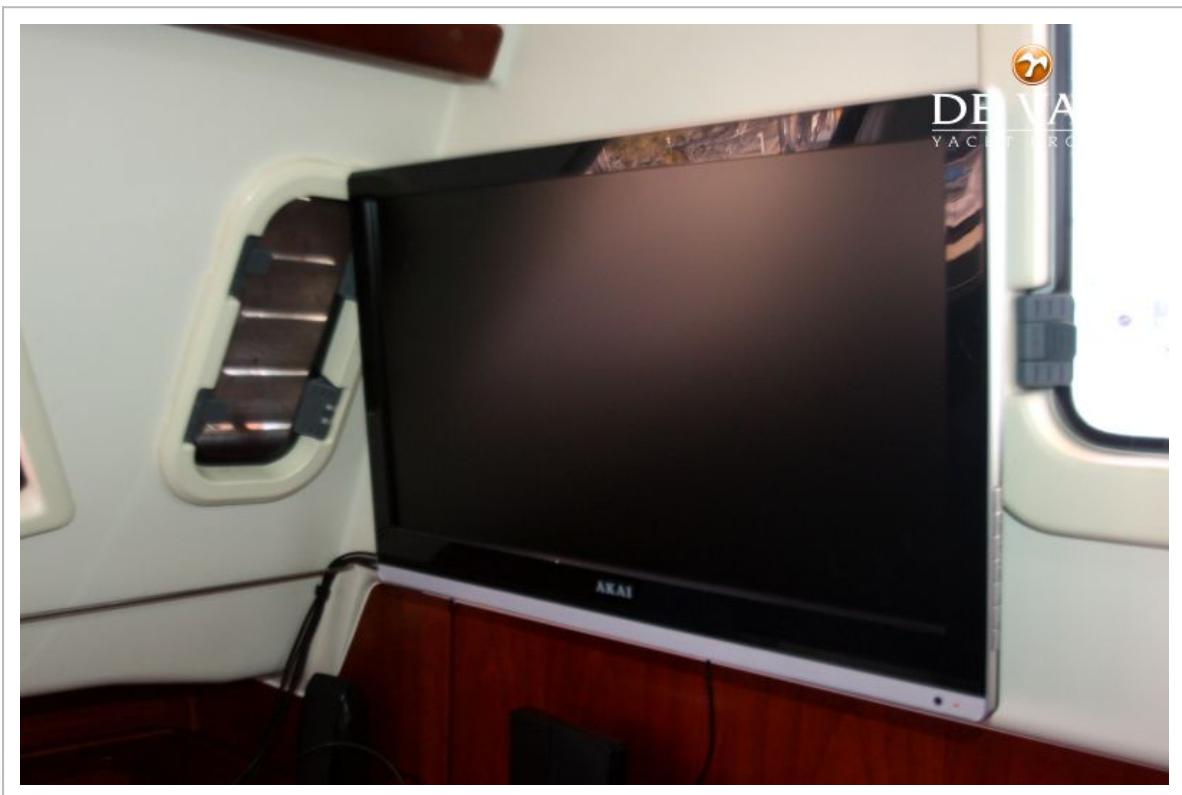

DEHLER 41 DS



DEHLER 41 DS

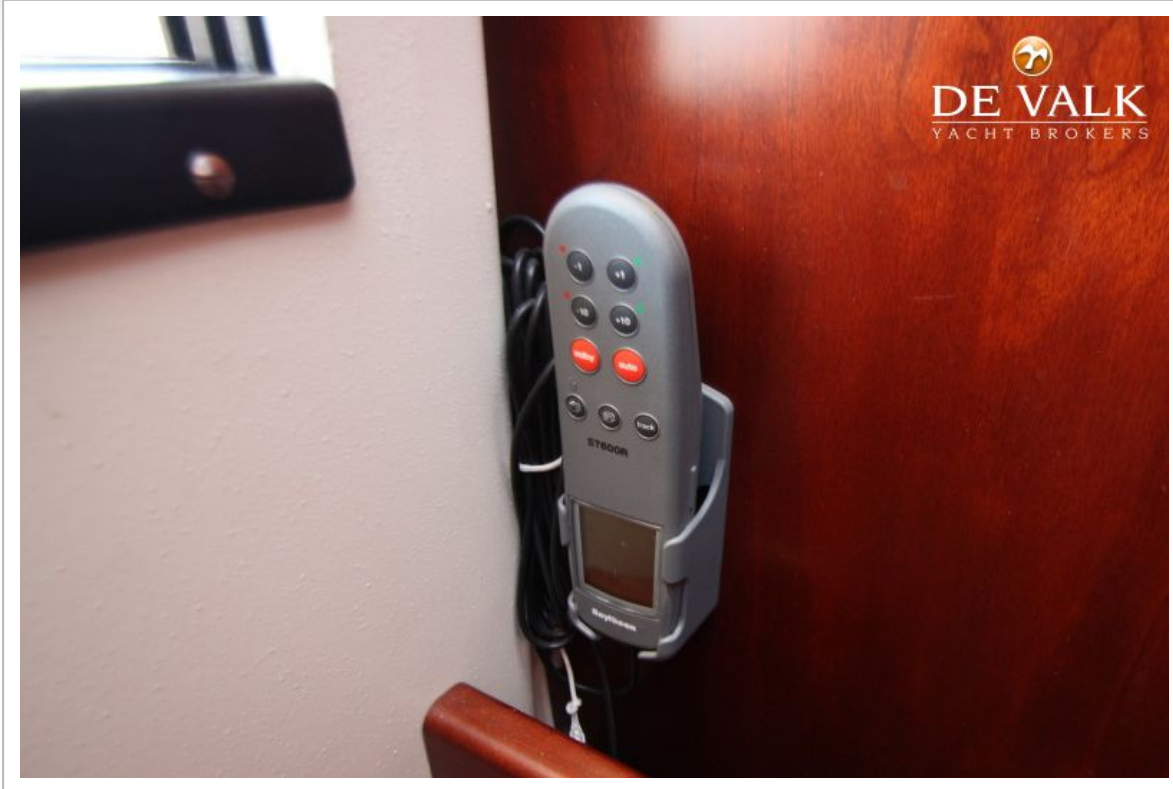

DEHLER 41 DS



DEHLER 41 DS

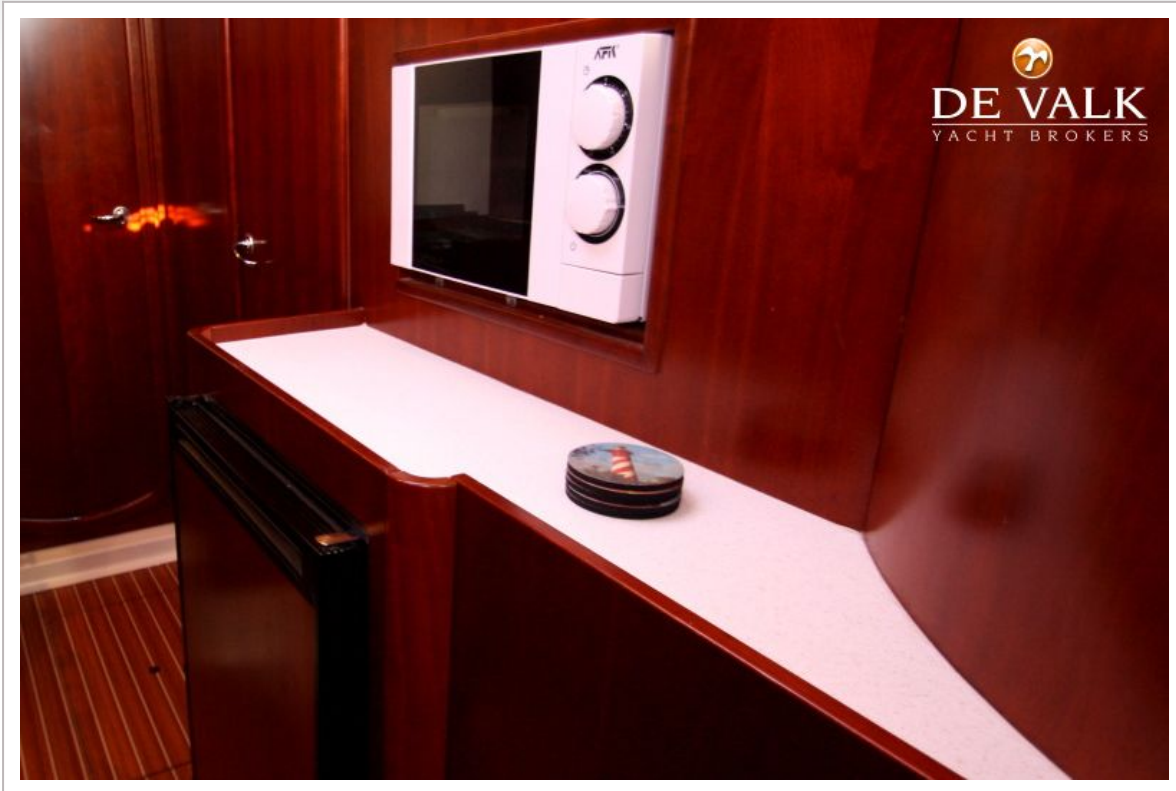

DEHLER 41 DS

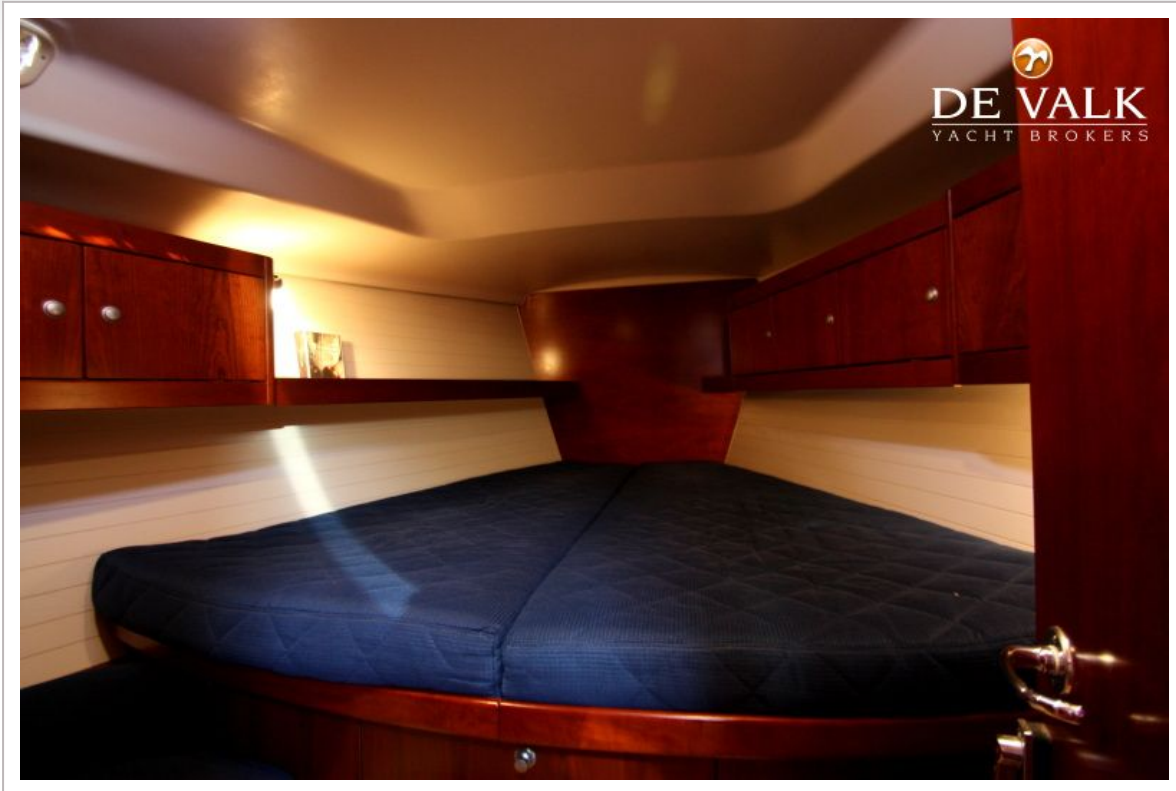

DEHLER 41 DS

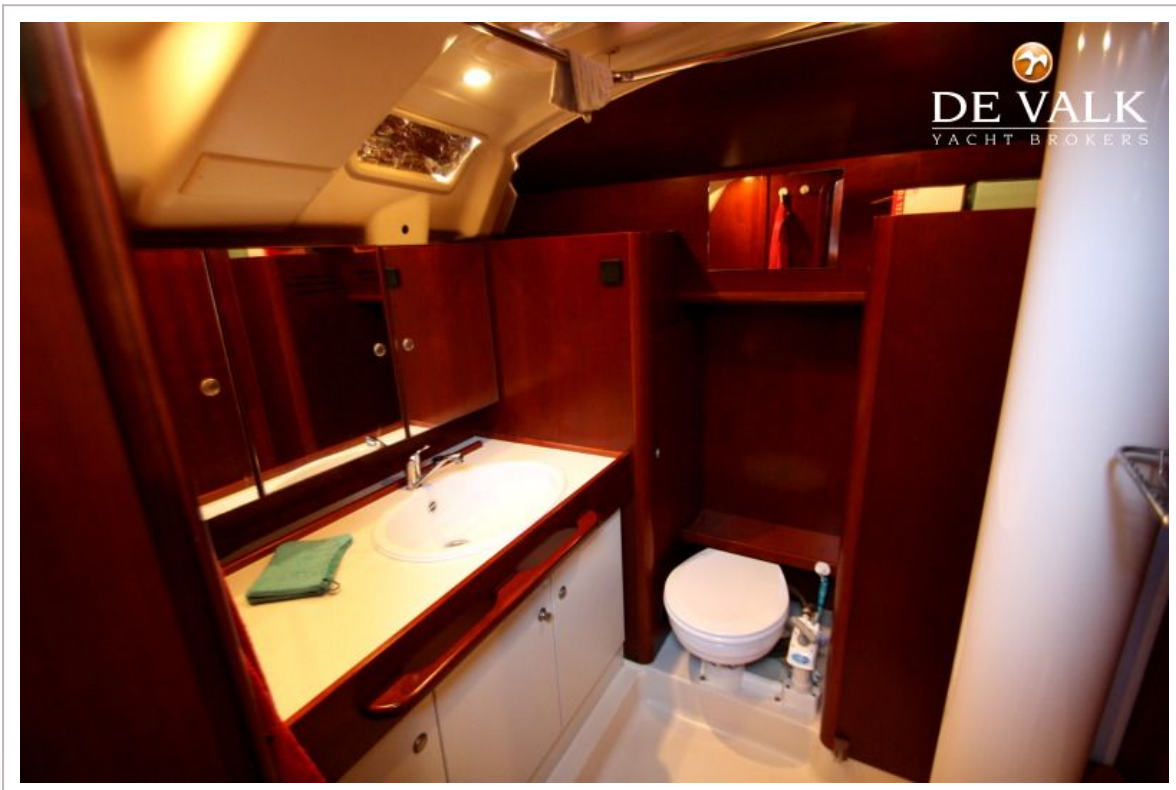

DEHLER 41 DS

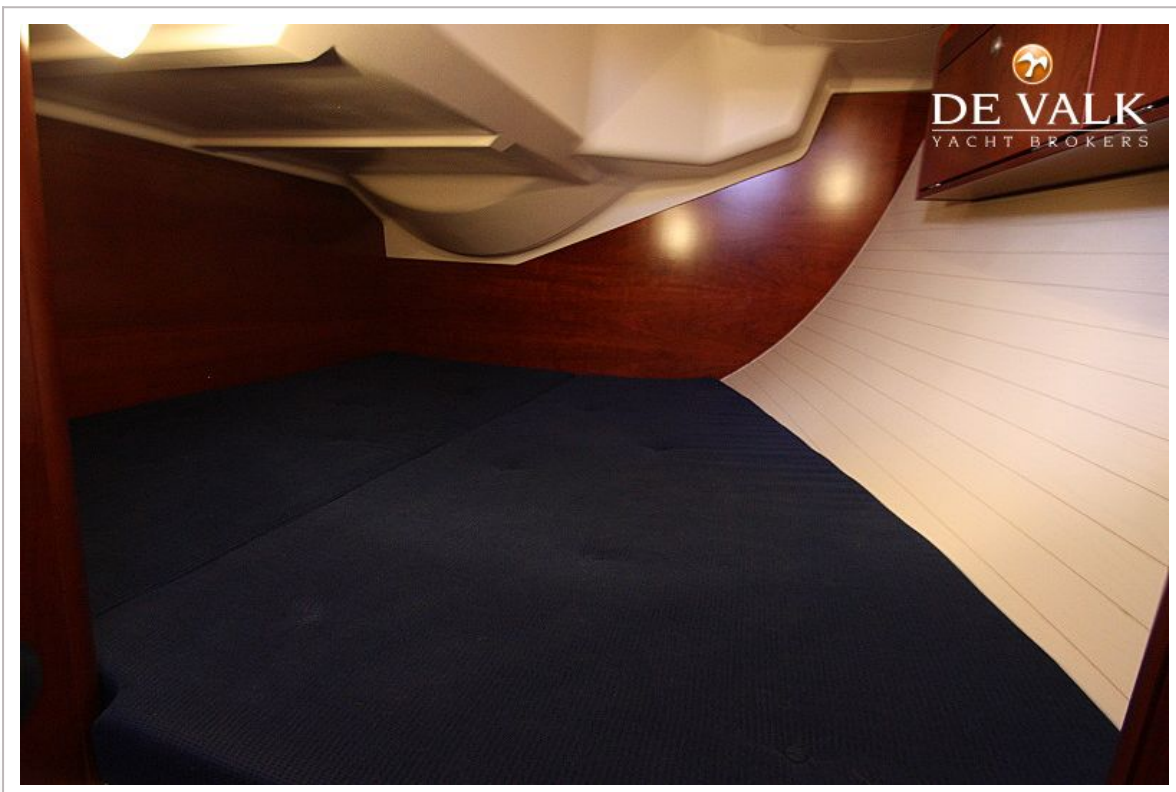
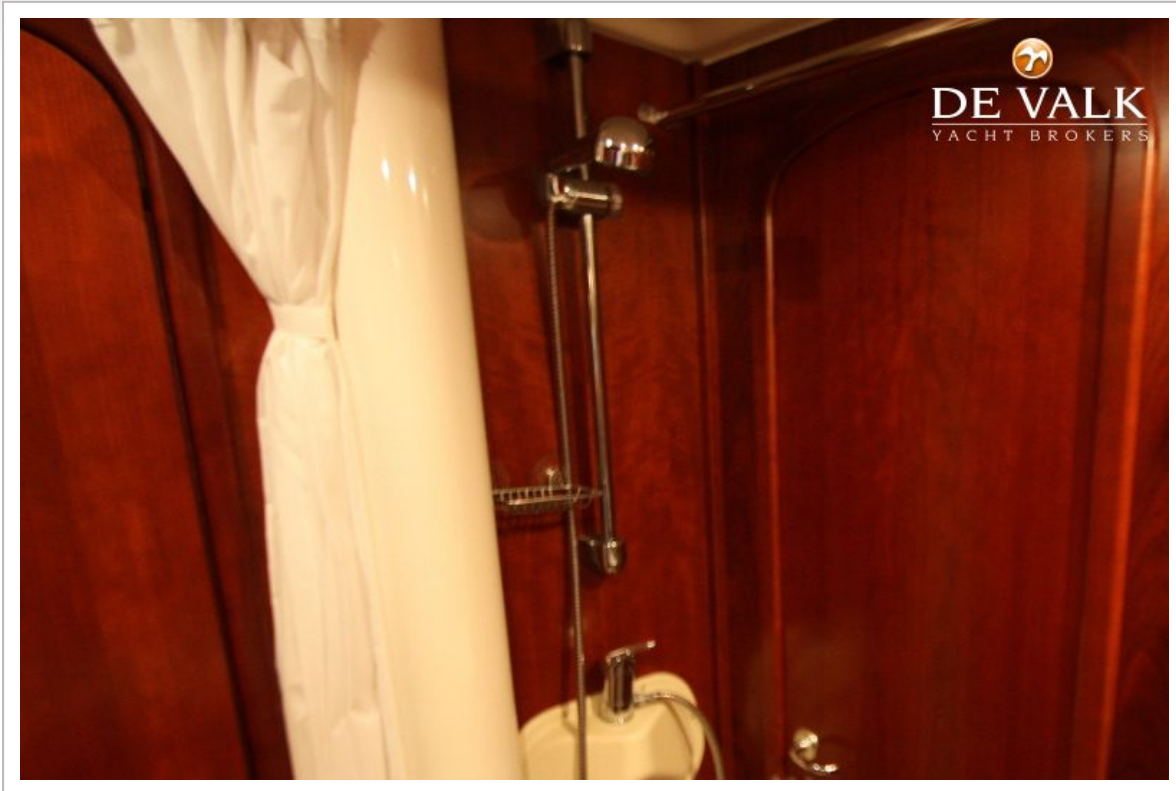

DEHLER 41 DS

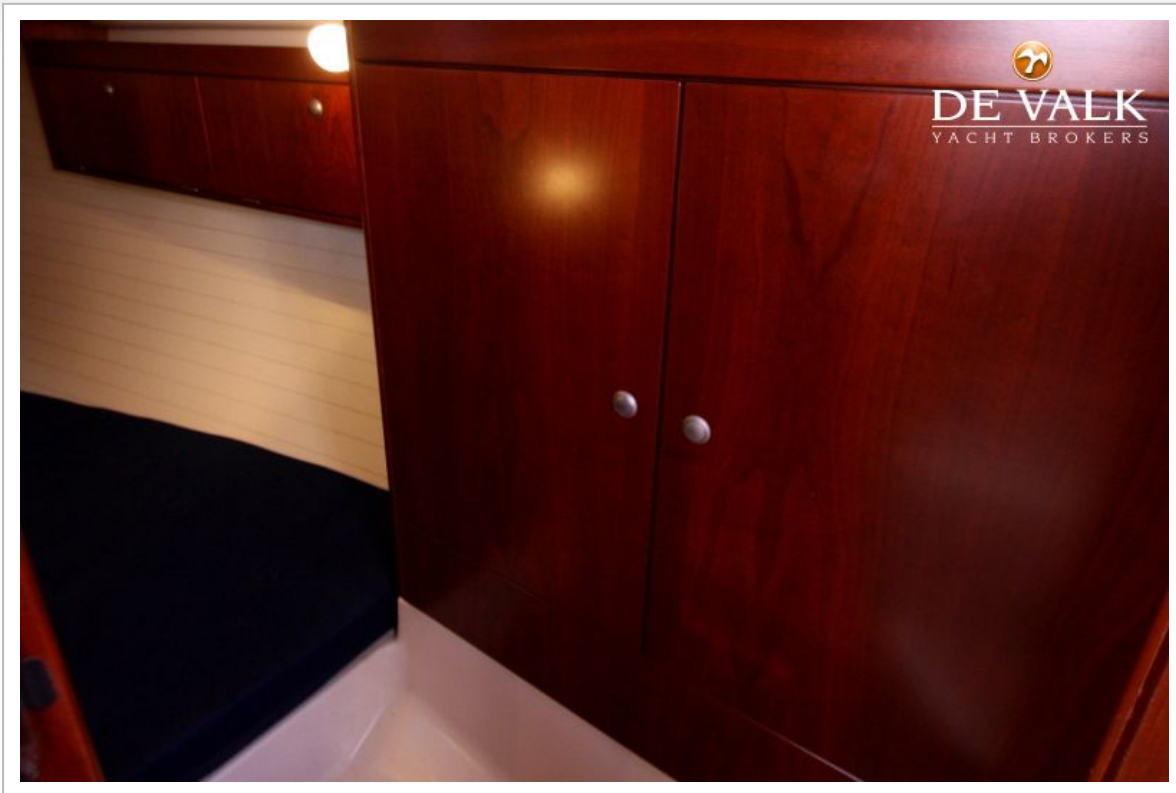

DEHLER 41 DS

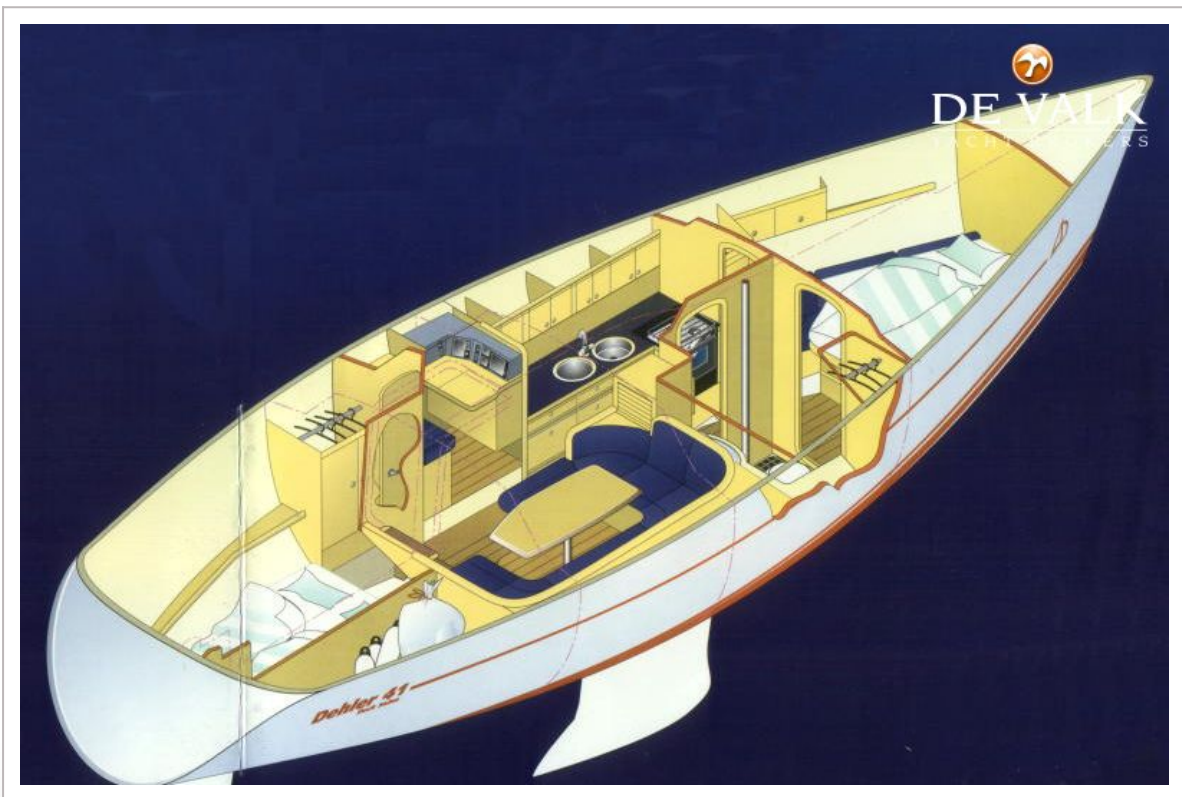
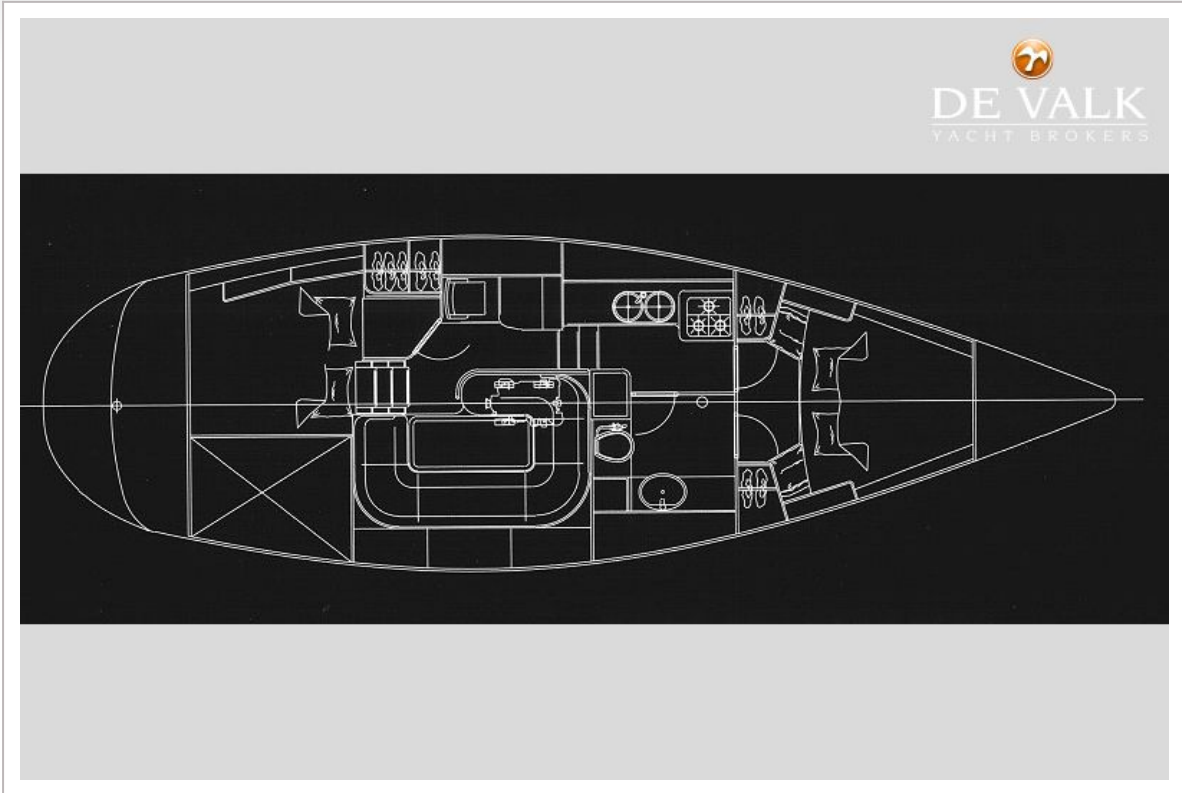

DEHLER 41 DS



DEHLER 41 DS

